

## 174-230MHz TV Panel Arrays

### Product Description

This series of panel antennas is ideal for four sided array design to provide a customized coverage for vertically polarized use in Band III. Model 659 has a nominal gain of 8dBd.

Construction from thick walled tube and solid steel bar gives a heavy duty panel which is designed for operation in very harsh environments. This design also ensures ideal hot dip galvanizing for optimum corrosion protection.

The coaxial feed system can be fully pressurized and features twin 'O' ring seals on the feed point insulators. The panels are tolerant of light icing (radomes are available for use under heavy icing conditions down to -40 degrees C) and have a very low VSWR (typically less than 1.05:1) over the entire 174 - 230MHz band depending on the system configuration.

These panels are ideal array elements having low sidelobes, low mutual couplings between panels and high power ratings across the full band. This results in complete antenna systems that have very wide VSWR and pattern bandwidth.

The ability to utilize larger tower cross sections allows support for a top mounted UHF antenna such as our PHP or PVP UHF antenna arrays. This provides a powerful combination for delivering DTV and/or DAB systems customized to suit the coverage requirements of the customer.



### Features

- Suitable for multi station use, DAB and DTV
- Vertical polarization
- Cyclone rated
- Rugged galvanized steel construction for maximum corrosion protection
- Low wind load
- Pressurizable coaxial feed
- Low VSWR full band operation
- Ideal array element allowing for a number of standard horizontal radiation patterns as well as customized patterns, contact RFS for details
- Medium power, unpressurized version available
- Temperature range -40 to +60 degrees C available

### Antenna Specifications

Frequency Range, MHz	174 - 240
Polarization	Vertical
Number of Channels	Multichannel
Nominal Gain (Mid-band), dBd	8.0
Half Power Beamwidth Azimuth, degrees	64
Return Loss, dB	26
Input Connector	7-16 DIN; 7/8" EIA Flange
Power Rating, kW	3; 4
Impedance, ohms	50 unbalanced
Weight, kg (lb)	35 (77)
Mounting (Standard), mm (in)	4 x 12mm (1/2) bolts
Effective Area Front (full antenna), sq m (sq ft)	0.40 (4.30)
Effective Area Side (full antenna), sq m (sq ft)	0.50 (5.38)
Design Wind Speed (max), km/h (mph)	240 (150)
Pressurization Operational, kPa (psi)	10 - 25 (1.5 - 3.8) 7/8" EIA Version
Pressurization Test, kPa (psi)	100 (15) 7/8" EIA Version
Material - Insulators	PTFE
Material - Radiators	Hot Dipped Galvanised steel
Material - Reflecting Screen	Hot Dipped Galvanised steel



174-230MHz TV Panel Arrays

Antenna Array Specifications

Number of bays	1				2				3			
	1	2	3	4	1	2	3	4	1	2	3	4
Panels per bay	1.6	1.6	1.6	1.6	1.6	1.6	1.6	1.6	1.6	1.6	1.6	1.6
Vertical Spacing between Bays (m)	6.9	3.8	3.0	1.7	6.9	3.8	3.0	1.7	6.9	3.8	3.0	1.7
HRP Directivity (dBd)	0.5	0.5	0.5	0.5	3.7	3.7	3.7	3.7	5.4	5.4	5.4	5.4
VRP Directivity (dBd)	7.4	4.4	3.5	2.2	10.5	7.5	6.7	5.4	12.3	9.3	8.4	7.1
Gain (times)	5.5	2.7	2.2	1.7	11.3	5.6	4.6	3.4	17.0	8.5	7.0	5.2
Weight (kg)	35	105	145	185	130	210	290	370	195	315	435	555
Weight (lbs)	77	232	320	408	287	463	639	816	430	695	959	1224
Antenna Aperture L (m)	1.6	1.6	1.6	1.6	3.2	3.2	3.2	3.2	4.8	4.8	4.8	4.8
Antenna Aperture L (ft)	5.2	5.2	5.2	5.2	10.5	10.5	10.5	10.5	15.7	15.7	15.7	15.7
Effective area (m2)	0.6	1.0	1.6	2.0	1.2	2.0	3.2	4.0	1.8	3.0	4.8	6.0
Effective area (ft2)	6.5	10.8	17.2	21.5	12.9	21.5	34.4	43.1	19.4	32.3	51.7	64.6
Windload @ 50m/s (kN)	0.9	1.5	2.4	3.1	1.8	3.1	4.9	6.1	2.8	4.6	7.3	9.2
Windload @ 50m/s (lbs)	206	344	550	688	413	688	1101	1376	619	1032	1651	2064

Number of bays	4				6				8			
	1	2	3	4	1	2	3	4	1	2	3	4
Panels per bay	1.6	1.6	1.6	1.6	1.6	1.6	1.6	1.6	1.6	1.6	1.6	1.6
Vertical Spacing between Bays (m)	6.9	3.8	3.0	1.7	6.9	3.8	3.0	1.7	6.9	3.8	3.0	1.7
HRP Directivity (dBd)	6.4	6.4	6.4	6.4	8.1	8.1	8.1	8.1	9.4	9.4	9.4	9.4
VRP Directivity (dBd)	13.3	10.2	9.4	8.1	15.0	12.0	11.1	9.8	16.2	13.2	12.4	11.1
Gain (times)	21.2	10.5	8.7	6.4	31.6	15.7	12.9	9.6	42.0	20.9	17.2	12.7
Weight (kg)	260	420	580	740	390	630	870	1110	520	840	1160	1480
Weight (lbs)	573	926	1279	1632	860	1389	1918	2448	1147	1852	2558	3263
Antenna Aperture L (m)	6.4	6.4	6.4	6.4	9.6	9.6	9.6	9.6	12.8	12.8	12.8	12.8
Antenna Aperture L (ft)	21.0	21.0	21.0	21.0	31.5	31.5	31.5	31.5	42.0	42.0	42.0	42.0
Effective area (m2)	2.4	4.0	6.4	8.0	3.6	6.0	9.6	12.0	4.8	8.0	12.8	16.0
Effective area (ft2)	25.8	43.1	68.9	86.1	38.8	64.6	103.3	129.2	51.7	86.1	137.8	172.2
Windload @ 50m/s (kN)	3.7	6.1	9.8	12.2	5.5	9.2	14.7	18.4	7.3	12.2	19.6	24.5
Windload @ 50m/s (lbs)	825	1376	2201	2752	1238	2064	3302	4127	1651	2752	4403	5503

Note: Tower sections and interface steelwork antenna system to tower is not included in load calculations.

Antenna Panel Dimensions

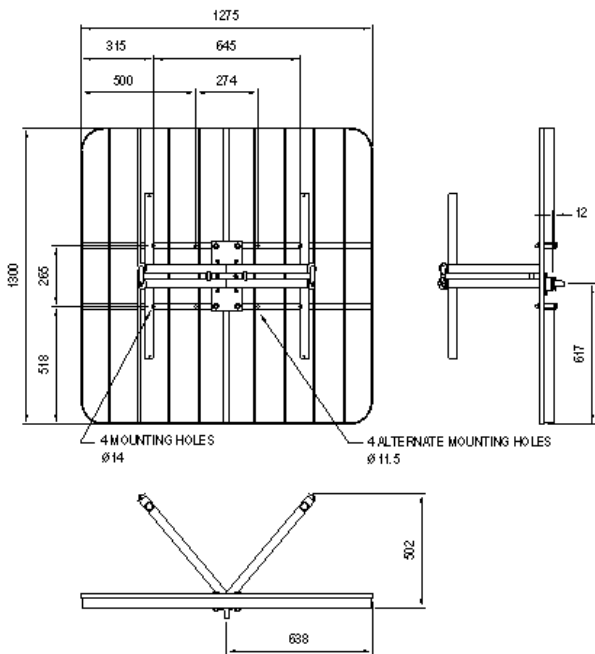

Nomenclature

Equal Split

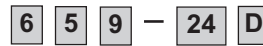

Number of faces: A=1, B=2, C=3, D=4, etc  
 Total number of Panels: 2, 4, 8, 12, 16 etc  
 659: Panel Series

Unequal Split

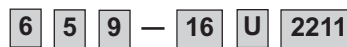

Power ratio per face  
 Unequal power ratio  
 Total number of Panels: 2, 4, 8, 12, 16  
 659: Panel Series

Thinned array

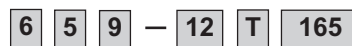

Panels per face  
 Thinned array  
 Total number of Panels: 2, 4, 8, 12, 16  
 659: Panel Series

All information contained in the present brochure is subject to confirmation at time of ordering

174-230MHz TV Panel Arrays

Horizontal patterns

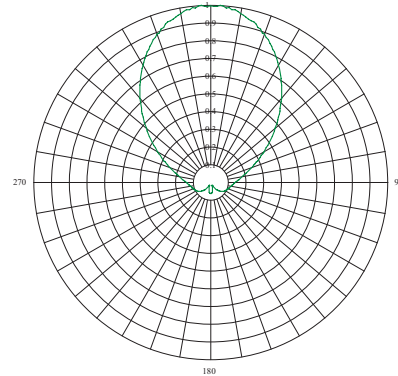
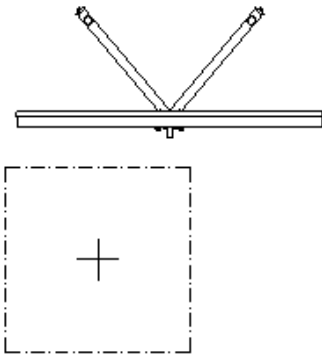

HRP 659-A 202MHz 6.87dBd

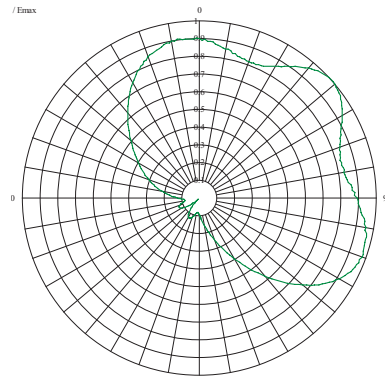
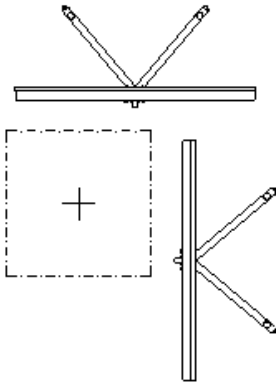

HRP 659-B 202MHz 3.84dBd

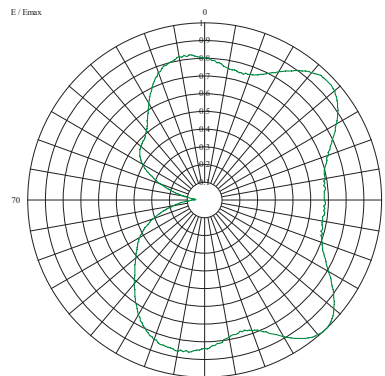
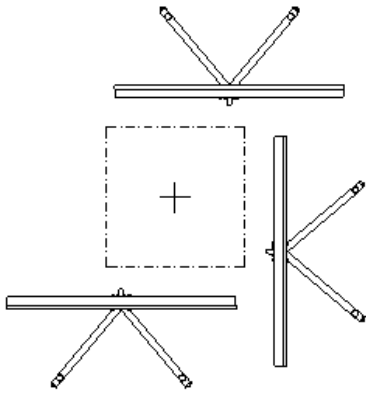

HRP 659-C 202MHz 3.00dBd

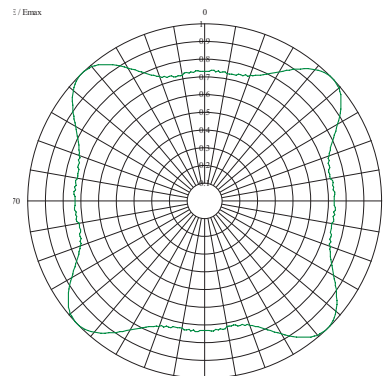
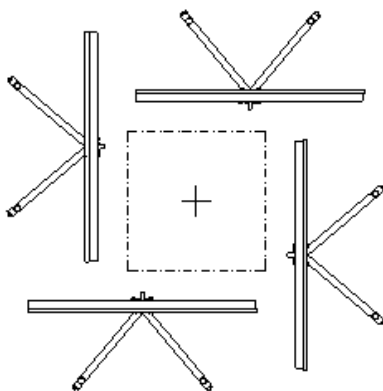

HRP 659-D 202MHz 1.69dBd

All information contained in the present brochure is subject to confirmation at time of ordering

174-230MHz TV Panel Arrays

Vertical patterns

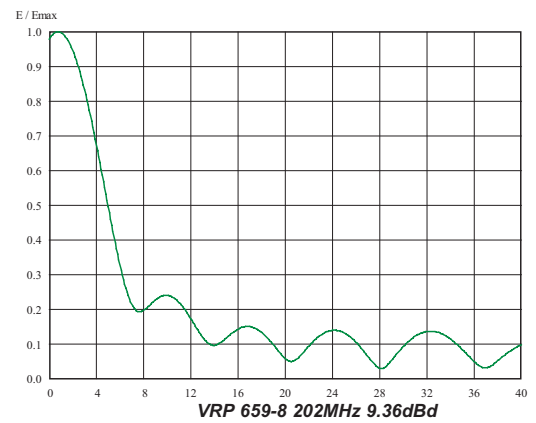
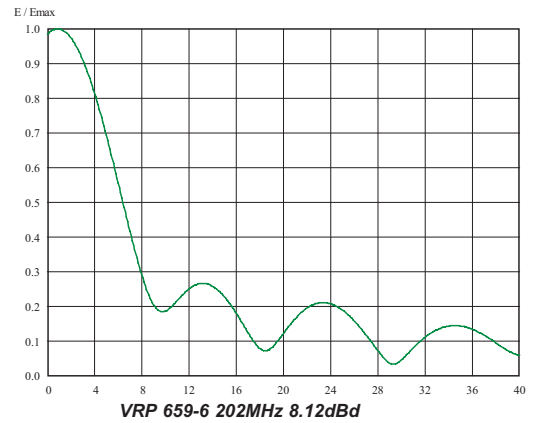
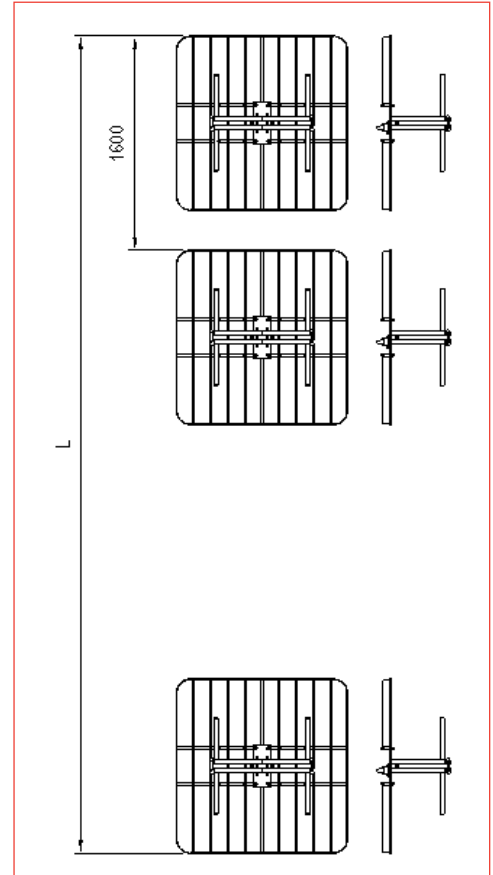
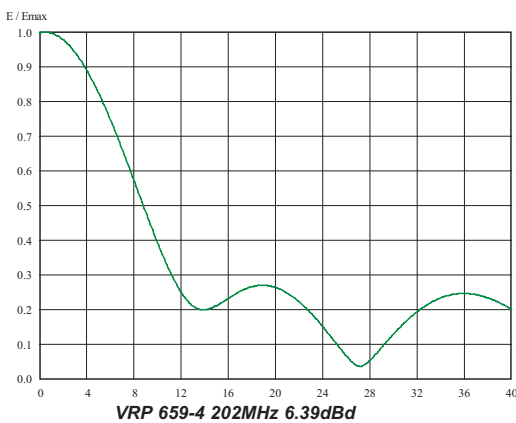
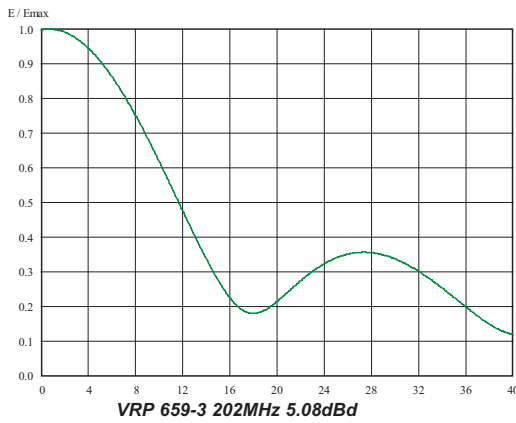
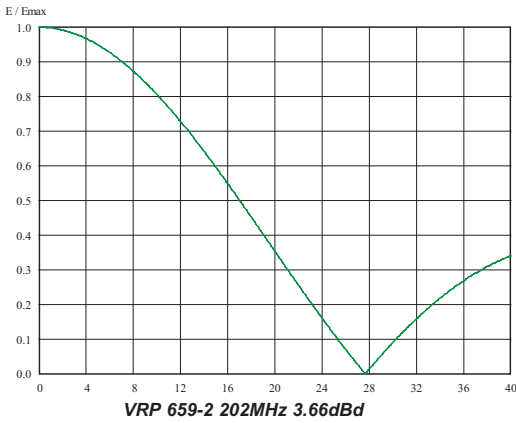
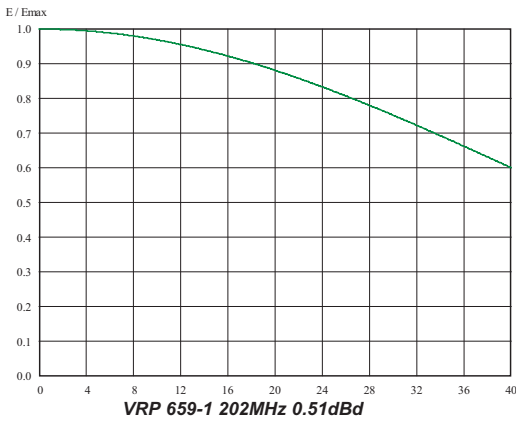

All information contained in the present brochure is subject to confirmation at time of ordering